



PRESS-FIT
CONNECTION
BALL VALVES
FOR WATER
SUPPLY

 **KEMBLA**

KemPress[®]
Ball Valves

KemPress® Ball Valves

HIGH QUALITY, FLAME-FREE, FLOW CONTROL BALL VALVES FOR THE KEMPRESS CONNECTION SYSTEM.

KemPress® is the system you know and trust. KemPress Ball Valves, as an extension to our KemPress system, are manufactured with the same features that create simplicity and peace of mind when using our system. KemPress Ball Valves are manufactured with press-fit technology and are the highest quality, flame-free and lead-free Ball Valves on the market.



WITH
UNPRESSED
FITTING ID
(LEAK PATH)



WaterMark

SAI Global WMK26653
AS 5830.1

KemPress® Ball Valves



KemPress® Ball Valves

THE UNIQUE DESIGN OF TWO PRESS ENDS MEANS YOU CAN GET THE JOB DONE MORE EFFICIENTLY AND EFFECTIVELY.

Designed with our renowned Unpressed Fitting ID Features, the KemPress Ball Valves contain a press connection that minimises the amount of pieces required for ball valves, which in turn, minimises the amount of leak points present in the system. KemPress Ball Valves are available in press connections with both male and female ends, ranging from ½ inch to 1 inch, and are suitable for use in potable water systems. Utilising a universal press profile and backed by a 5-Year Warranty, KemPress Ball Valves offer you the most reliable and trusted press-fit system. Check out some of the unique features and benefits of KemPress Ball Valves.

BALL VALVE FEATURES



TWO PRESS ENDS

The unique design of two press ends means you can get the job done more efficiently and effectively. Being a one-piece valve with less threads and press ends, minimises the potential for leakage in the system. It also eliminates the need for a hot works permit and allows a completely flame-free environment, assisting with risk minimisation and control.



UNPRESSED FITTING ID

Utilising our unique Unpressed Fitting ID that can be seen on all our KemPress Fittings, allows a small amount of water or air to escape from any fitting that is un-pressed.

This feature ensures a system isn't commissioned with unpressed fittings installed that under high pressure may cause a temporary seal and cause a future leak and reduce the risk of costly failures, rectification and damage to property.

The leak path feature is activated by performing a low-pressure test prior to normal pressure testing.



LEAD-FREE

Meeting the requirements of safe drinking water standards, our Ball Valves are manufactured with lead-free material CW724R which offers great corrosion resistance to all types of potable waters and eliminates the risk of lead contamination in household drinking water.



UNIVERSAL PRESS PROFILE

KemPress Ball Valves have been specifically designed with a unique press profile making it universally compatible with all tools in the Australian market.

KemPress® Ball Valves

BALL VALVE BENEFITS

- Fast and easy to use
- Improve installation quality
- Minimise risks during and after installation
- Now includes leak before pressing 'Unpressed Fitting ID'
- Flame-free connection – no hot works permits required
- High quality fittings
- Universal fitting profile - approved to work with all major press-fit tools in Australia and fittings designed to work with all copper tube compliant to AS 1432
- Less opportunity for unnecessary system leaks because of their press ends (compared to traditional threads).
- 5 Year Warranty



KemPress® Ball Valves

PRODUCT RANGE

KEMPRESS BALL VALVES	Item Code	Product Description	Diameter (DN)	Lever Type	Carton Qty
Press x Press Lever Handle	J06650	15 x 15 KemPress Brass Ball Valve (Water)	15 x 15	T Handle	8
	J06651	20 x 20 KemPress Brass Ball Valve (Water)	20 x 20	T Handle	8
	J06652	25 x 25 KemPress Brass Ball Valve (Water)	25 x 25	T Handle	8



Press x Male BSP T- Handle	J06656	15 x 1/2" BSP Male KemPress Brass Ball Valve (Water)	15 x 1/2" BSP	T Handle	8
	J06657	20 x 3/4" BSP Male KemPress Brass Ball Valve (Water)	20 x 3/4" BSP	T Handle	8



Press x Female BSP T- Handle	J06658	15 x 1/2" BSP Female KemPress Brass Ball Valve (Water)	15 x 1/2" BSP	T Handle	8
	J06659	20 x 3/4" BSP Female KemPress Brass Ball Valve (Water)	20 x 3/4" BSP	T Handle	8



Press x Press T- Handle	J06660	15 x 15 KemPress Brass Ball Valve (Water)	15 x 15	T Handle	8
	J06661	20 x 20 KemPress Brass Ball Valve (Water)	20 x 20	T Handle	8



KemPress® Ball Valves

PRODUCT MEASUREMENTS

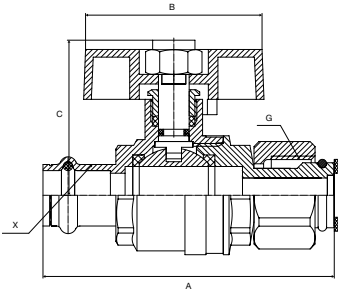

PRESS x SWIVEL NUT & TAIL - T-HANDLE

Product Code	A	B	C	X	G
J06653	75.9	46	40.4	15	1/2" BSP
J06654	86	46	40.4	15	3/4" BSP
J06655	86	46	40.4	20	3/4" BSP

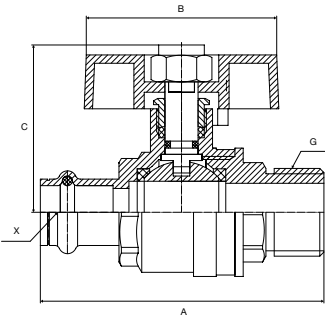

PRESS x MALE BSP - T-HANDLE

Product Code	A	B	C	X	G
J06656	68.5	46	40.4	15	1/2" BSP
J06657	80.5	46	40.4	20	3/4" BSP

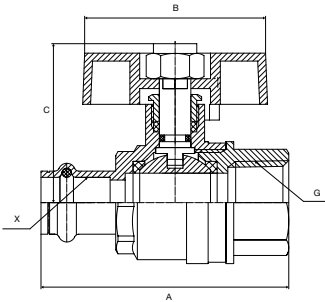

PRESS x FEMALE BSP - T-HANDLE

Product Code	A	B	C	X	G
J06658	63	46	40.4	15	1/2" BSP
J06659	73.5	46	40.4	20	3/4" BSP

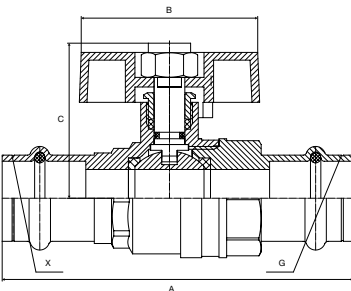

PRESS x PRESS - T-HANDLE

Product Code	A	B	C	X
J06660	78	46	40.4	15
J06661	91.5	46	40.4	20

INSTALLATION GUIDE

DN15-25 VALVE INSTALLATION

The following is a step by step guide to installing the Kembla® Valve System for diameters DN15-25. For projects requiring maintenance and repair visually inspect the copper tube to ensure it is in reasonable condition with no signs of external corrosion or scores. Installation shall be in accordance with Australian standards and the KemPress® Ball Valve Installation Guide. Failure to adhere to either can result in the warranty being voided.



STEP 1. Refer to design guidelines overleaf for important dimensions which must be considered prior to installation. Use only Type A & B copper tube complying with AS 1432. Cut copper tube to required length using a pipe cutter.



STEP 2. Carefully deburr the end of the tube on the inside to minimise turbulence and pressure loss according to AS3500 and on the outside to avoid damaging the O-ring.



STEP 3. For existing copper tube installations, ensure that the copper tube complies with AS 1432 and is free of defects and in good condition (no deep scratches). Clean the end with emery paper or a soft scourer.



STEP 4. Measure and mark the insertion depth by lining up the fitting side by side with the tube or measure and mark the tube as per the below insertion depth table. When the fitting is inserted onto the tube the outer edge of the fitting must line up with the marking.



STEP 5. Select pressing jaw according to the fitting dimension and insert into the pressing machine. Arrest the locking bolts of the machine. Check the jaws are free from debris and in good working order.



STEP 6. Ensure you have the correct valve fitting for the application (e.g. water or gas). Check the fitting is clean and the O-ring is free from debris and correctly sitting in place. Push fitting on tube all the way to the engagement marking. Recheck engagement with the pipe prior to pressing.



STEP 7. Open the pressing jaw and close it around the fitting so the raised bump in the fitting rests inside the groove of the pressing jaw. Ensure the jaw is engaged square with the fitting and not on an angle. Check the fitting outer edge still lines up with the engagement mark.



STEP 8. Initiate the pressing job by pressing the start button. The automatic pressing process guarantees a tight connection. The pressing process can be interrupted by pressing the emergency-stop button.



STEP 9. Visually inspect the fitting to ensure the press has been completed. The KemPress® tool will flash if the fitting did not press correctly. If this occurs a new valve fitting and tube section is required. At the end of the project visually inspect each fitting to ensure none have been missed.

INSTALLATION GUIDE

SPACE REQUIREMENTS

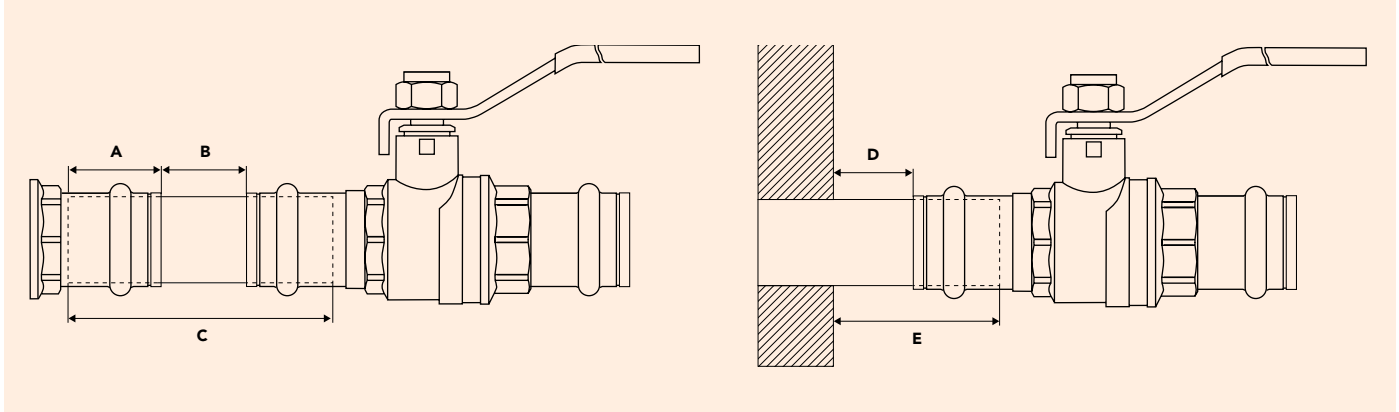

MINIMUM DISTANCES

The table below shows the minimum distances required between a press joint and other objects.

Nom. Size mm	Tube OD mm	A mm	B mm	C mm	D mm	E mm
DN15	12.70	17.6	10	45.2	60	77.6
DN20	19.05	21.8	10	53.6	60	81.8
DN25	25.40	23	10	56	60	83

INSERTION DEPTHS

Size (DN)	15	20	25
Insertion depth mark (mm)	17.6	21.8	23

BRAZING & SOLDERING

Brazing or soldering near to KemPress® joints should be avoided as this may cause the seal to degrade due to heat transfer.

The table below states the minimum distance away from the press joint which is acceptable to braze. If this distance cannot be maintained then adequate precautions must be taken such as fabricating the brazed section prior to assembly with the press fittings, wrapping the press joint in a wet rag and keeping cool during brazing or applying tube freezing spray.

Tube Size	DN15	DN20	DN25
Min. Clearance to existing connection (mm)	350	500	650
Min. Clearance to existing brazed fitting (mm)	10	10	10

KEMPRESS BALL VALVES ARE NOT SUITABLE FOR:

Solar hot water systems, medical gases, refrigeration and air conditioning gases, acetylene, urea solution, glycerin triacetate, coolant inhibitor, sodium hydroxide or ammoniac gases.

THREADED END CONNECTIONS

All threaded male and female connections are BSPP "G" threads and are to only be used with compatible threaded connections.

Swivel nut ball valves are supplied with a flat washer required for use when installing. Please ensure a flat washer is present prior to and during installation.

WATER FITTINGS

Application	Max. Operating Pressure KPa	Max. Operating Temperature C
Hot & cold potable water	1600	95
Chilled water	1600	-25
Rainwater installations*	1600	Ambient
Vacuum	- 80	Ambient
Domestic fire sprinkler systems and fire hose reel	1600	Ambient
Compressed air installations (oil free)	1600	70

* The composition of untreated supplies and bore water should be examined to ensure compatibility with copper prior to installation of piping. Untreated tank water may not be compatible with copper due to the lack of stability and potential microbiological variability.

Tools compatible with KemPress® Ball Valves

KemPress® KPS, KPS2, KPL, KPL2, KPL3 & KPXL
Viega Picco & Picco 6 Plus, Pressgun 4B, 5 & 6
Novopress ACO102, ACO202, ACO203, ECO202 & ECO203
Ridgid RP 210-B & RP 340
Milwaukee M12 & M18 Force Logic
Rothenberger Compact and ROMAX 3000 & 4000

KemPress® Ball Valves

WARRANTY

Ball Valves Warranty

All KemPress Ball Valves come with a 5 Year Warranty. An intensive ISO 9001 certified quality control system is applied to all KemPress Ball Valves and extensive testing and approvals.

MM Kembla warrants that if any installation using KemPress Ball Valves becomes defective or fails and MM Kembla is notified of the details and is satisfied that the defect or failure was a result of a manufacturing defect and not the result of faulty specification, installation or incompatible environment, MM Kembla will replace or repair the defective goods and make good the installation.

For full details of the MM Kembla warranty please see: <http://www.kembla.com.au/support/trading-terms> and download the **Standard Conditions of Sale for Goods.**"



Caution

Product data, design details, performance figures, advice and other information given herein (the "Information") is provided only as a guide to available information.

MM Kembla does not accept any liability whatsoever (including arising from negligence) for the accuracy of the Information and for injuries, expense or loss, which may arise as a result of the use of the Information by the recipient.

For further information

Refer to the current edition of **The Plumbers Handbook** available through your MM Kembla representative or contact Customer Service.

FREQUENTLY ASKED QUESTIONS

Q1: What standard of copper tube are KemPress Ball Valves compatible with?

A: KemPress Ball Valves are suitable for use with AS1432 type A and B copper plumbing tube in the annealed, half hard (bendable) and hard drawn tempers.

Q2: Can KemPress Ball Valves be used on Chrome Plated Copper Tube?

A: Yes, however it is recommended to test a piece first as some splitting of the chrome plating may occur.

Q3: What is the testing process for your "Un-Pressed Fitting ID" feature (or leak path)?

A: Unpressed fittings are able to be identified by pressurising the system at target pressures of 100kPa for water. A leak or pressure drop should be evident. Final pressure testing of the system should be conducted in accordance with AS/NZS 3500 and/or AS/NZS 5601 once the low pressure leak testing has been completed.

It's also recommended that you employ a "visual inspection" check. It is obvious if the fitting has been pressed or not. Good practice has been to mark the fitting after pressing or inspection with a marker or paint to indicate all fittings have been pressed and inspected.

Q4: Can the KemPress Ball Valves be pressed more than once?

A: No. Repeated pressing can incorrectly deform the fitting, affect the seal and create a leak.

Q5: Can KemPress Ball Valves be used for Refrigeration gases?

A: No the fittings cannot handle the higher pressure. Maximum pressure is 1600kpa.

Q6: Can KemPress Ball Valves be used for Medical gases?

A: No, KemPress Ball Valves are not approved for use in the Australian Medical Gas Installation Standard AS2896. Only Silver brazing alloy (15% silver content) is to be used to connect copper tube and fittings for Medical Gas applications.

Q7: Do you have to use Kembla Copper tube with KemPress Ball Valves?

A: KemPress Ball Valves are suitable for use with any AS1432 type A and B copper plumbing tube in the annealed, half hard (bendable) and hard drawn tempers.

If you use Kembla Copper Tube you get one warranty from one supplier and KemPress Ball Valves have been developed and optimised for use with high quality Kembla Copper Tube.

Q8: Is de-burring the copper tube essential?

A: It is essential. Failing to De-bur can result in leaking pipes and void the warranty.

Q9: Can you press KemPress Ball Valves directly against each other?

A: No. Minimum distance is 17.6mm for DN15 and 21.8mm for DN20 & 23mm for DN25.

Q10: Can you use KemPress Ball Valves on Oxygen, Hydrogen or Helium?

A: Yes but not for medical gas installation purposes.

Q11: If there is movement in the KemPress Ball Valve what should I do? Will it leak?

A: As long as you have full engagement of the fitting on the tube and relevant low pressure tests and full pressure testing have been completed and passed. That means the fitting must be inserted up to the witness mark. If you do not have a witness mark then re-do the fitting to be safe.

Q12: Once pressed, the tube shape looks to have changed. Is that normal?

A: Yes, the compression of the fitting onto the tube enables the connection to be permanent. There is no change in performance for water flow and friction loss.





KemPress[®] Ball Valves



**HIGH QUALITY,
FLAME-FREE
FLOW CONTROL.**

KEMPRESS[®] BALL VALVES

KemPress Ball Valves are manufactured with press-fit technology and are the highest quality, flame-free and lead-free Ball Valves on the market. Utilising a universal press profile and backed by a 5-year warranty, KemPress Ball Valves offer you the most reliable and trusted press-fit system.

www.kembla.com.au



MM Kembla
Gloucester Boulevard,
PO BOX 21, Port Kembla, NSW 2505
T: 1800 804 631
F: 1800 817 846
E: sales@kembla.com.au
www.kembla.com.au